



MARINE COMPACT LED LANTERN

MCL 180



The MCL 180 is a compact LED marine lantern, solar self-contained, with great optical efficiency and low consumption, fitted with LED diodes of high intensity, reaching a maximum range of 8 nautical miles and offering a big autonomy.

Its luminous source consists of an innovating lens system especially designed to take the maximum profit of LED diodes, thus obtaining an output of up to 180 Cd/W.

The battery is replaceable, thus the complete lantern disposal is not necessary at the end of battery's life. Standard fixings allow for a quick beacon replacement.

Designed according to IALA Recommendations.

FEATURES

- ✓ High-efficiency luminous system.
Up to 6 nm ($T=0.74$), 8 nm ($T=0.85$).
- ✓ Vertical divergence up to 12° .
- ✓ 360° horizontal output.
- ✓ Average operation lifetime over 10 years.
- ✓ IP 68 watertightness degree (immersion resistant).
- ✓ Very resistant to marine environment.
- ✓ RS-232 serial port for setting adjustments by PC.
- ✓ Programming, configuration and operating status via PC, IR programmer or Bluetooth as an option.
- ✓ Autonomy without solar charging up to 400 hours.
- ✓ Automatic energy management, according to latitude.
- ✓ 4 nos. solar modules of 2W each.
- ✓ **PATENTED OPTICAL SYSTEM.**



MARINE COMPACT LED LANTERN

MCL 180



Specifications subject to change without previous notice. Luminous ranges will be affected depending on latitude, flash rhythms and chosen options.

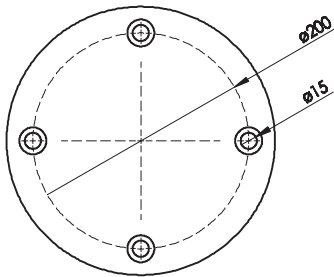
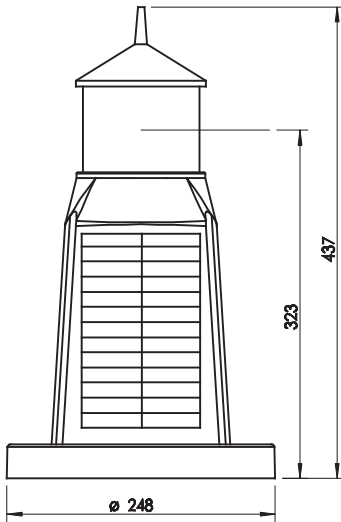

Optical System	
Light source:	3 to 6 nos. ultra-bright LED diodes, with high-precision acrylic lens.
Luminous range:	Up to 6 nm (T=0.74) 8 nm (T=0.85).
Colours available:	White, green, red, amber and blue.
Vertical divergence:	From 5° to 12° (50% lo).
LED average life:	More than 100,000 hours.

Electronic control	
Flash rhythms:	256 (6 nos. user selectable).
Day/night threshold:	Adjustable in lux.
Solar charge regulation function:	Regulation in 3 phases.
Settings:	PC / IR programmer (optional Bluetooth).
Energy management:	Dynamic, according to latitude.
Light intensity reduction due to low battery:	Configurable by the user.

Solar modules and battery	
Solar modules:	4 nos. of 2W each.
Battery:	12 Ah, gelled, maintenance-free.
Autonomy without solar charging:	Up to 400 hours.

Materials and environment	
Base:	Glass-fibre reinforced polyamide PA66-GF30.
Lens cover:	Acrylic, UV stabilised.
Vibration resistance:	MIL-STD-202G, Method 204D (5G).
Shock resistance:	MIL-STD-202G, Method 213B.
Watertightness degree:	IP 68.
Fixings:	4 bolts in a 200mm diameter.
Humidity resistance:	100%. Pressure-compensation valve to avoid condensation.
Temperature range:	From -20° to 70°C.
Inside hardware:	Stainless steel.

Options
Infrared (IR) programmer.
PC programming kit.
Bluetooth programming.
Fixing kit for 3 bolts in a 200mm diameter.
Other specifications available under request.

MCL 180	PEAK INTENSITIES (Cd)	
	VERTICAL DIVERGENCE 5°	VERTICAL DIVERGENCE 12°
White	169	97
Green	166	109
Red	120	70
Amber	176	73

Other divergences available.



MEDITERRÁNEO SEÑALES MARÍTIMAS, S.L.L.
 mesemar@mesemar.com • www.mesemar.com

